

HCS1857BL

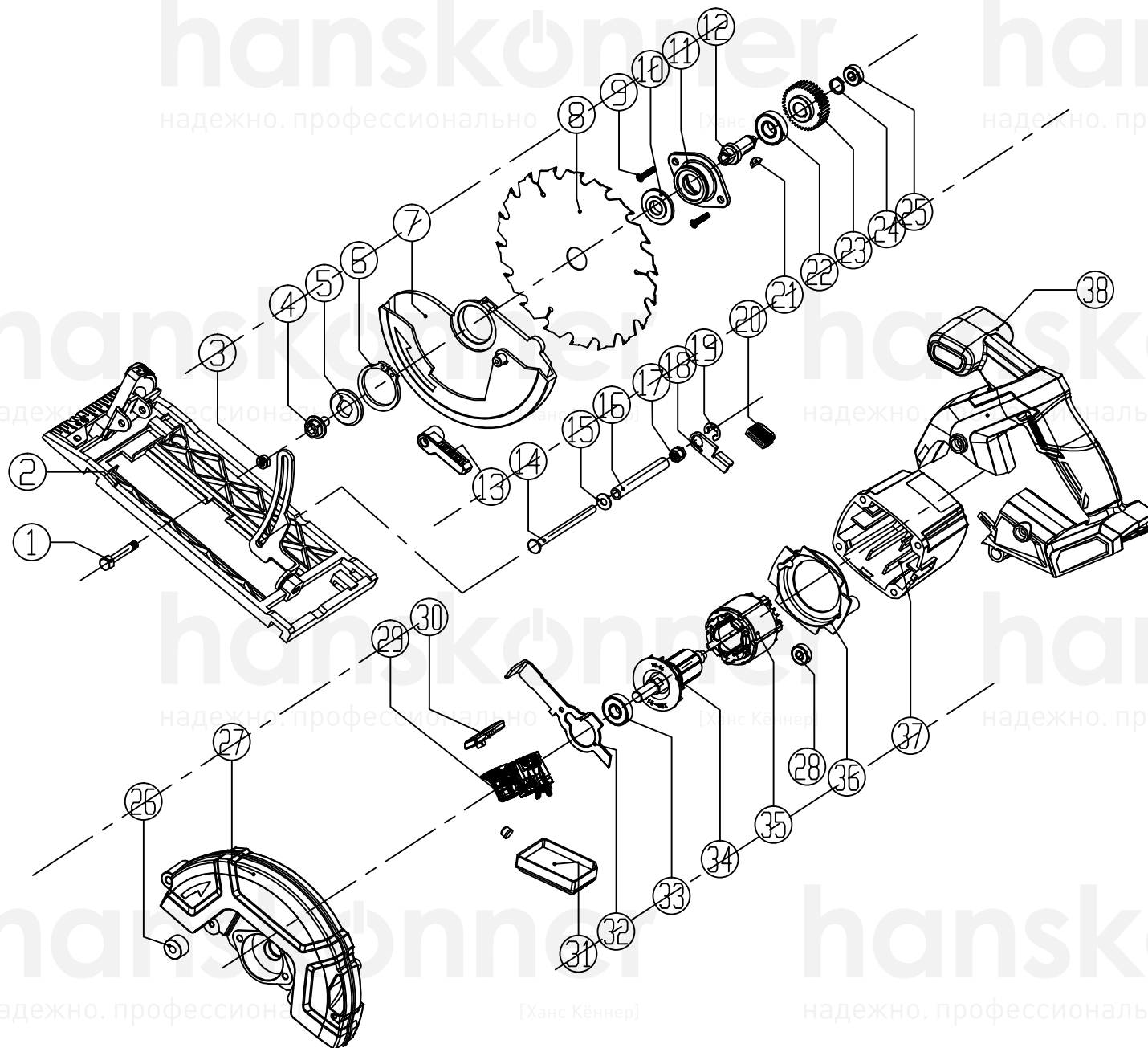

No	Description
1	screw
2	base
3	nut
4	flange screw
5	outer flange
6	circlip
7	moving guard
8	blade
9	screw
10	down flange
11	gear box
12	spindle
13	moving guard handle
14	long screw
15	washer
16	screw sleeve
17	nut
18	angle adjustment knob
19	circlip
20	knob cover
21	key
22	bearing 6001RS
23	gear
24	circlip
25	bearing 606Z
26	block
27	fixed guard
28	bearing 607RS
29	switch
30	safety rod
31	motor PCB
32	spindle lock
33	bearing 6000RZ
34	rotor
35	stator
36	wind guide
37	motor housing
38	handle

RU-HS20191101